

M6 FIXINGS  
 DOME NUT NYLON 77  
 SPRING WASHER  
 HALF NUT  
 PTFE WASHER  
 1/4 LARGE FLANGE WASHER

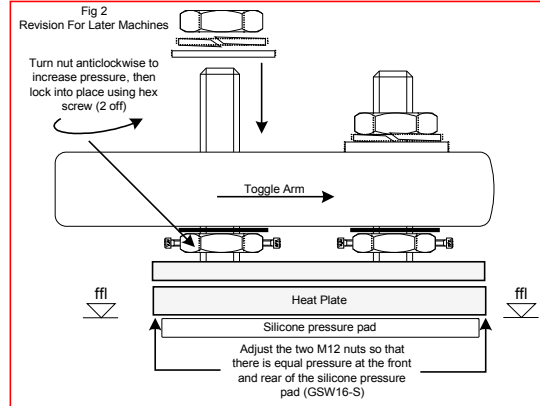

Studding all bright zinc plated.		Microseal <b>Plus</b> Parts Assembly			
Metric fasteners all bright zinc plated.		© WADER Labelling Systems Limited			
Engineering Department	SIZE Metric	Date 04/08/2009	DWG NO Microseal Plus Assembly	REV 6	
Roy Goodier	SCALE	NTS	In House	SHEET 1 OF 1	

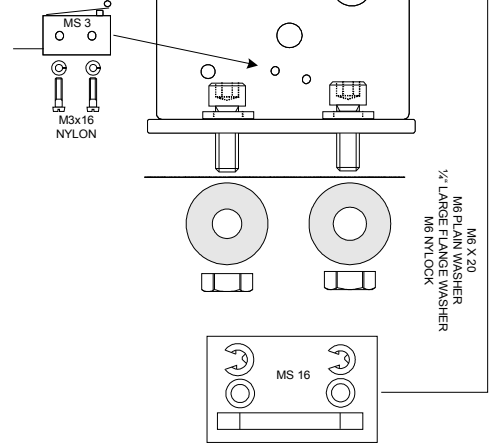
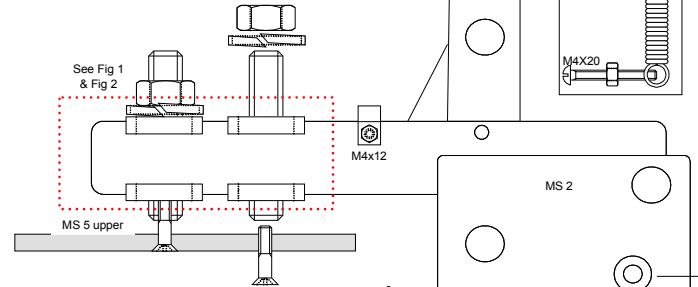
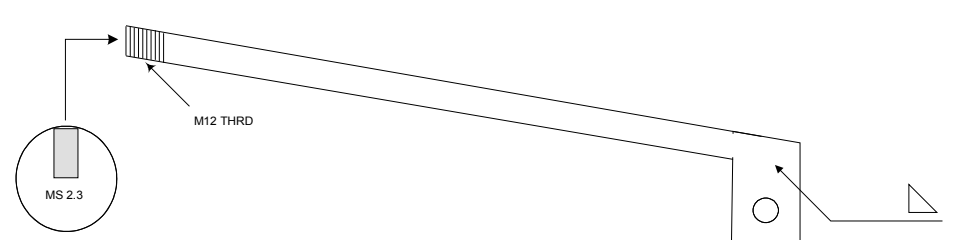
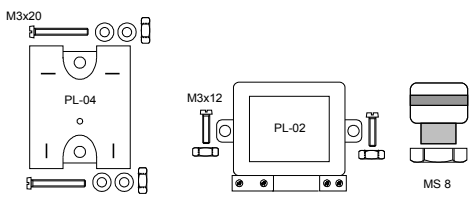
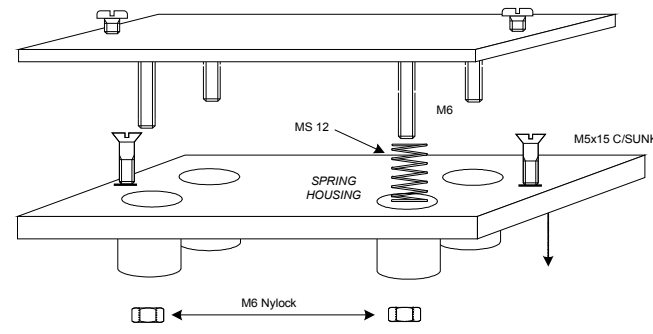
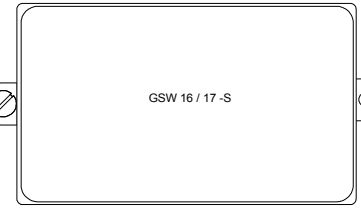
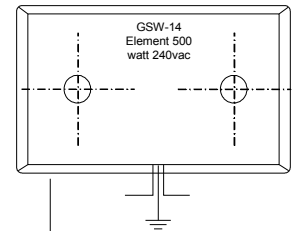
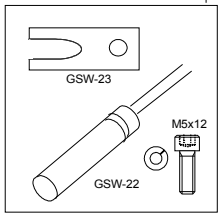
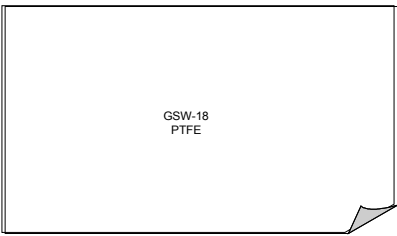
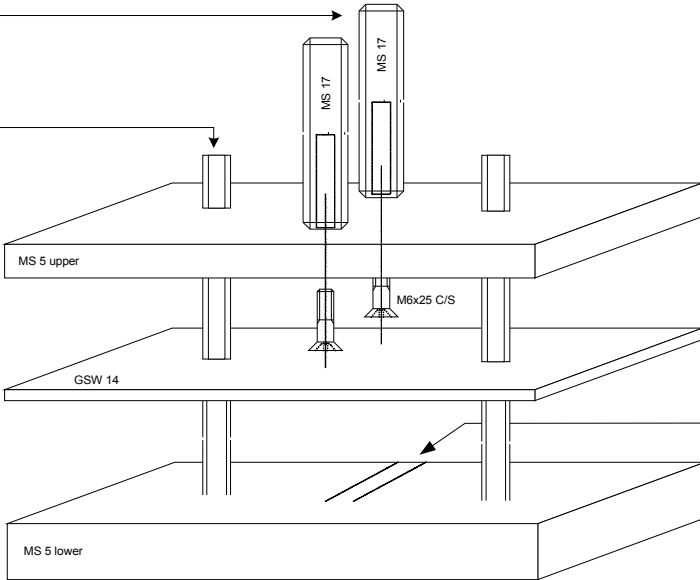
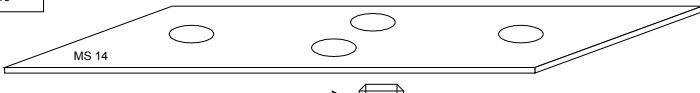
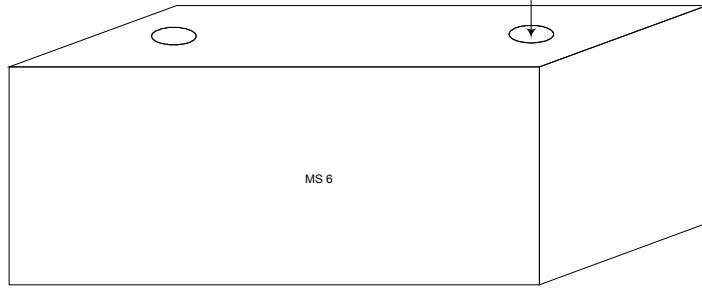
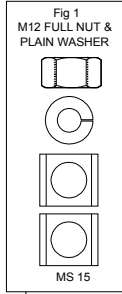
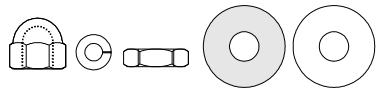